

HYDRAULIC POWER SLIP

Model : ABHPS -27

We make Hydraulic Power Slip (ABHPS-27) is a fully automatic, remote controlled, Hydraulic operated Power Slip and designed to handle drill pipe & tubing with a size range from 3-1/2" to 5 1/2" by changing inserts. This slip is suitable for 27 1/2" / 37 1/2"- 49 1/2" Rotary Table equipped with API standard Pin Drive Master Bushing. Power Slip is set by gravity plus applied hydraulic pressure and released by applied hydraulic pressure. This Power Slip can be controlled either by hand lever or remote control.

Features :

- a) Compact design & lesser height.
- b) Can be operated by single person.
- c) Can be controlled from safer distance.
- d) Solution for crew safety at rig floor.



Model : ABHPS-27

Figure No. 35

The unit consists of five major assemblies as under: -

1. Top Cover Assembly:

The Top Cover Assembly is designed in two halves. The flat, top surface is designed to accommodate TDS elevators while drilling to the floor. The rod ends of the two hydraulic cylinders connect the top of the cover assembly with a ball floating joint fitted with hex-head screws. Top Cover Assembly is having four clevises for mounting slip assembly hangers and two holes that accommodate the guide rods.

2. Slip Assembly:

Four slip segments of 1 6 1/2" grip length for gripping the tubular sizes are dressed with 48 no. inserts, 4 no. Insert Retaining Ring and 8 nos. Allen screw.

3. Bowl Assembly:

The Bowl Assembly consists of two halves connected with a bowl hinge pin to enable the installation and removal of the power slips from Master Bushing. Two guide rods and two hydraulic cylinders are connected to the top cover assembly to provide stability.

4. Hydraulic Cylinders Assembly:

Assembly consists of two double acting hydraulic cylinders to lift the Top Cover Assembly with slip assembly, approximately 8-1/2" on the application of designed pressure. The hydraulic cylinders are fitted in the bowl body. Corrosion resistant SS guide rod and floating ball joint are also provided to support the hydraulic cylinders.

5. Hydraulic Power Unit:

Hydraulic Power Unit can be located in the driller's console, enabling the driller to operate the slips. The control system consists of Pump, Filter, Pressure Gauge, Oil level indicator, flow control valve etc.

MEROL ENERGY SERVICES PRIVATE LIMITED

Part List of Hydraulic Power Slip

S.No.	P/N	Description	Qty. Per Unit
1.	HPS - 21	Top Cover	1 No.
2.	HPS - 22	Hydraulic Cylinder Unit	2 No.
3.	HPS - 23	Floating Joint	2 No.
4.	HPS - 24	Floating Joint Bolt	2 No.
5.	HPS - 25	Slip Hanger	4 No.
6.	HPS - 26	Slip Hanger Top Pin w/Cotter Pin	4 No.
7.	HPS - 27	Slip Hanger Bottom Pin w/Cotter Pin	4 No.
8.	HPS - 28	5½" Slip Segment to handle 4½" – 5½" Drill Pipe	4 No.
9.	HPS - 29	4½" Slip Segment to handle 3½" – 4½" Drill Pipe	4 No.
10.	HPS - 30	Slip Bowl (One set of Two pcs.)	1 set
11.	HPS - 31	Bowl Hinge Pin	1 No.
12.	HPS - 32	Guide Pin	2 No.
13.	HPS - 33	Guide Pin Bush	2 No.
14.	HPS - 34	Guide Pin Bolt	2 No.
15.	HPS - 35	Hydraulic Power Unit	1 No.
16.	HPS - 36	Lifting Sling (Four Hooks Type)	1 No.
17.	HPS - 37	Hydraulic Hose Unit consists of Hoses, Couplings, Connectors, Flow Control Block and with divider	1 No.
18.	5163	Inserts to handle 3½" Drill Pipe for Slip Body Size 4½" (One set consists of 08 no. of Inserts)	04 Set
19.	5163-B	Inserts (Taper Design) to handle 3½" Drill Pipe for Slip Body Size 4½" (One set consists of 04 no. of Inserts)	04 Set
20.	5164	Inserts to handle 4" Drill Pipe for Slip Body Size 4½" (One set consists of 08 no. of Inserts)	04 Set
21.	5164-B	Inserts (Taper Design) to handle 4" Drill Pipe for Slip Body Size 4½" (One set consists of 04 no. of Inserts)	04 Set
22.	5165	Inserts to handle 4½" Drill Pipe for Slip Body Size 4½" (One set consists of 12 no. of Inserts)	04 Set
23.	5168	Inserts to handle 4½" Drill Pipe for Slip Body Size 5½" (One set consists of 08 no. of Inserts)	04 Set
24.	5168-B	Inserts (Taper Design) to handle 4½" Drill Pipe for Slip Body Size 5½" (One set consists of 04 no. of Inserts)	04 Set
25.	5169	Inserts to handle 5" Drill Pipe for Slip Body Size 5½" (One set consists of 08 no. of Inserts)	04 Set
26.	5169-B	Inserts (Taper Design) to handle 5" Drill Pipe for Slip Body Size 5½" (One set consists of 04 no. of Inserts)	04 Set
27.	5170	Inserts to handle 5½" Drill Pipe for Slip Body Size 5½" (One set consists of 12 no. of Inserts)	04 Set

Exploded View of Hydraulic Power Slip

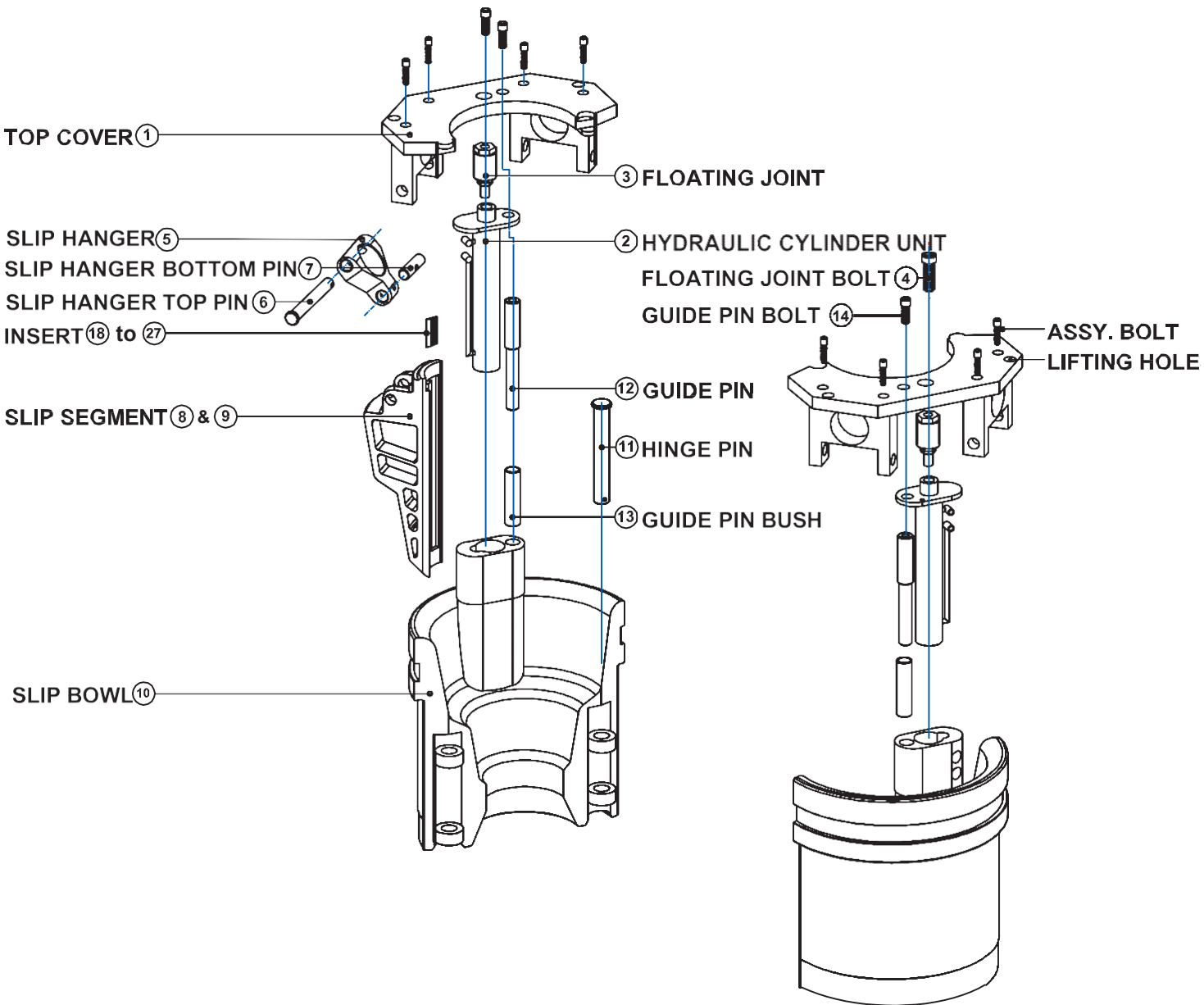

Figure No. 36